

*Paige Stainless Heelguard* - 'Civil trough and grate'.

Plan view

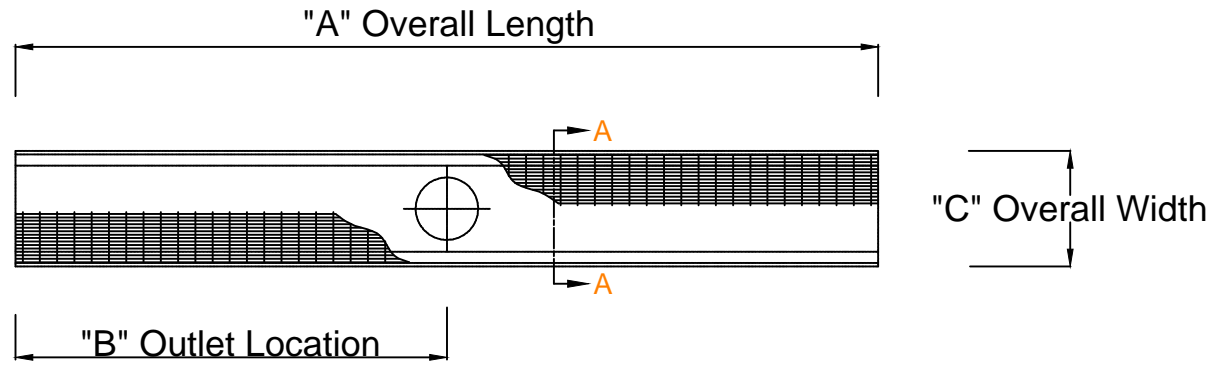

Elevation view

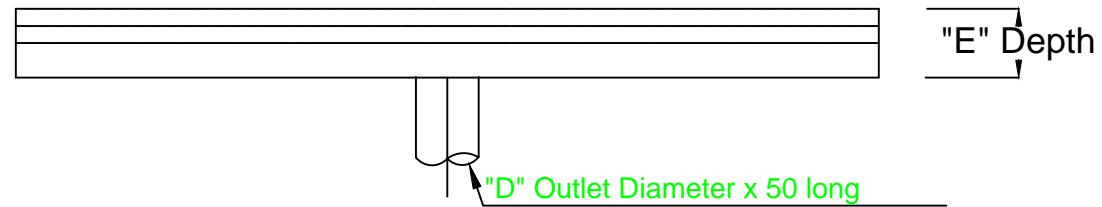

SECTION A-A HEELGUARD GRATE

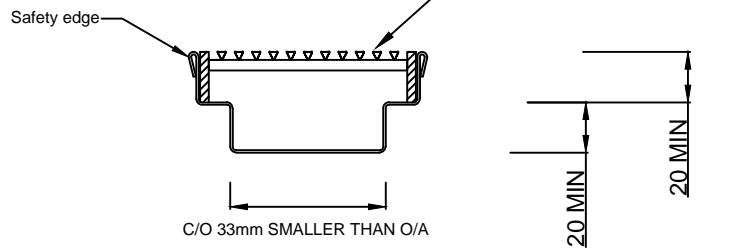

FUNCTIONAL DIMENSIONS					Load class- A,B,C,D.
"A"	"B"	"C"	"D"	"E"	

\*NOTE - Depth may vary with load class.



THIRD ANGLE PROJECTION

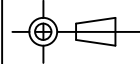

CONTROLLED DOCUMENT  
NO UNAUTHORISED COPYING

27 CESSNA DRIVE  
CARBONVILLE QLD. 4510.  
PH. 0754 991 511  
FAX. 0754 990 741  
P.O BOX 153  
BURPENHAY 4505

*Paige Stainless Fabrications.*  
**PAIGE STAINLESS PTY. LTD.**  
ABN: 75 066 083 510